

Installation Manual



Press Brake Control Model 3400

Completely prewired and ready for installation.



Easy mounting into an existing control panel.

Revision Number	Revision Date	Authorized Name	Description	Filename
1.0	08/07/01	LH	New Format of Manual	28-015.pdf
1.1	10/11/01	DK	Addition of new Warning paragraphs (warning page, installation page, and back page)	Model_3400_28-015r1-1.pdf
1.2	05/25/05	AJR	Revised Page Numbers	Model_3400_28-015r1-2.pdf
1.3	02/22/10	DK	Revision of Appendix C	Model_3400_28-015r1-3.pdf
1.4	5/14/10	DK	Page 3: Addition of 52-119 CPU / Input Board Page 4: Addition of 52-120 Power / Output Board	Model_3400_28-015r1-4.pdf
1.5	8/20/2010	DK	--Addition of Warning on Actuating Press Valves --Page 5: Warning on Rotary Cam Installation Addition --Page 7: Warning on Linear Limit Switch Installation Addition --Page AC 1 and AC 2: Warning on Linear Limit Switch Installation Addition NEMA Control Wiring Diagrams Addition	Model_3400_28-015r1-5.pdf
1.6	9/15/2010	DK	Appendix C: Included additional valve "warnings."	Model_3400_28-015r1-6.pdf
1.7	10/18/2011	DK	Appendix C: Updated drawings on pages AC-3 to AC-6	Model_3400_28-015r1-7.pdf

Machinery Guards and Controls

✓ for
info

- Safety Light Curtains
- Safety Mat Systems
- Ergonomic Palm Buttons
- Punch Press Guards and Controls
- Press Brake Guards and Controls
- Robotic and FMS Guarding Systems
- PressCam 8-“Control Reliable” Punch Press Automation Controller:** Programmable Limit Switch, 16 Station Die Protection System, Time-Based Brake Monitor, Five Counters, Servo-Feed Interface, Tonnage Monitoring, 150 Job Memory, 8” Operator Screen

Please send me information on the above marked items

Name:	_____
Title:	_____
Company:	_____
Address:	_____

City, State, Zip:	_____
Phone:	_____
Fax:	_____
Email:	_____

Fax your request to 412-262-1197



America's Machine Guarding/Machine Control Company
P.O. Box 9306, Pittsburgh, Pennsylvania 15225
800-937-4334 412-262-1115 FAX: 412-262-1197

sales@triadcontrols.com www.triadcontrols.com



Press Brake Control

Model 3400

Installation Manual

Triad Controls, Inc.
3715 Swenson Avenue
St. Charles, IL 60174

P/N: 28-015r1-7

Customer Service: 630-443-9320 (CST)
(Please have Model #, Serial #, and Software Rev # Available)

Sales and Marketing: 800-937-4334 (EST)

Proper Use and Limitations

The information disclosed herein includes proprietary rights of the manufacturer. Neither this document nor the information disclosed herein shall be reproduced or transferred to other documents, used or disclosed to others for manufacturing purposes, or for any other purposes, except as specifically authorized in writing by the manufacturer. If this manual is supplied in connection with the sale or delivery of manufacturer's equipment, it is to be used solely for maintenance, repair or installation of such equipment.

The Press Brake Control Model 3400 is to be used on part revolution air clutch press brakes. Before installation or using your Press Brake Control system, be sure you follow the described requirements:

- The Press Brake Control must be installed by qualified personnel.
- The press on which the Press Brake Control is installed must meet ANSI B11.1-1988 and OSHA 1910.217 regulations which include inspection and maintenance procedures that must be followed to meet these regulations. The manufacturer will NOT take responsibility for improperly maintained machinery.
- Point of operation safeguarding is spelled out in ANSI B11.19-1990. This regulation is used to determine a safe distance to place palm buttons, mechanical guards, safety curtains, and mats. Such equipment can be provided by the manufacturer but the Press Brake Control is not in itself a safeguarding device. The manufacturer takes no responsibility for operator injury as a result of improper safeguarding.
- The Press Brake Control may not be able to safely stop a press which has a faulty stopping mechanism. The manufacturer cannot be held responsible for an improperly maintained or working stopping mechanism.
- The Press Brake Control must be checked out before put into use. Follow this manual for procedures on how to do this.
- The Press Brake Control should not be modified or repaired except by qualified personnel and upon authorization of the manufacturer. Never operate machinery that is not in full working order.
- Make sure that all maintenance people, machine operators, die-setters, foremen, and supervisors have read and understand this manual.
- All procedures in this manual must be followed. All procedures in manuals of equipment attached to this Press Brake Control must be followed. The manufacturer cannot take responsibility for operation of the Press Brake Control if all procedures and warnings listed in all manuals are not followed.

Limitation of Liability

We have designed our equipment to the very highest performance and safety standards known to the current technological state of the art. However, the installation, usage, suitability, and fitness of our equipment for any purpose, known or unknown, is interdependent upon the performance of other equipment not manufactured, installed, or secured or maintained by the manufacturer.

We cannot and do not accept responsibility for any overall system performance when factors, such as these, are beyond our control.

In the event of any claim for breach of any obligations of manufacturer under any order, whether expressed or implied, and particularly in the event of any claim of a breach of the warranty or warranties contained in the paragraph "WARRANTY" or of any other warranties, expressed or implied which might despite the paragraph entitled "DISCLAIMER," be determined to be incorporated in any order, the company shall under no circumstances be liable for any consequential or special damages, either in law or in equity, or for losses or expenses or claims for the same arising from the use of, or inability to use, the products of the manufacturer for any purpose whatsoever.

WARNING: The entire machine safety system must be tested at the start of every shift. Machine testing should include: (1) proper machine operation and stopping capability; and (2) verification of proper installation and settings of all point of operation guards and devices before the operation is released for production.

Warranty

Manufacturer warrants that this product will be free from defects in material and workmanship for a period of two years on the Press Brake Control and one year on components from the date of shipment thereof. Within the warranty period, manufacturer will repair or replace such products which are returned with shipping charges prepaid and which will be disclosed as defective upon examination by the manufacturer. This warranty will not apply to any product which will have been subject to misuse, negligence, accident, restriction, and use not in accordance with manufacturers instructions or which will have been altered or repaired by person's other than the authorized agent or employees of the manufacturer.

Disclaimer

The provisions of the paragraph "WARRANTY" are the sole obligations of the manufacturer and exclude all other warranties of merchantability, expressed or implied. Further, there are no warranties which extend beyond the above warranty.

WARNING on ACTUATING PRESS VALVES

Control Reliability requires that all Press's use only monitored DUAL SAFETY VALVES for the CLUTCH and monitored DUAL SAFETY VALVES on the BRAKE systems. Never operate a Press that uses a monitored DUAL SAFETY VALVE system on the CLUTCH but not the BRAKE (or vice versa). Dual Safety Valves used on press clutch/brake applications must be rated by the manufacturer for use on press clutch/brake applications.

Overview

Control Box Features	1
Control Station Features	1

Options

BM-1600 Brake Monitor	2
SuperLight VI Safety Light Curtain.....	2
Zone Control (mat control)	2

Installation

52-119 CPU / Input Board	3
52-120 Power / Output Board	4
Control Box	5
Electrical Wiring	5
Interlocks.....	5
Clutch Solenoid Valve	5
Disconnect Switch.....	5
Limit Switches/Encoder Box	5
Rotary Cam Switch Unit.....	5
Actuator Arm Limit Switch	5
Operator's Station	6
Emergency Stop Buttons	6

Alignment and Setup

Adjusting the Limit Switches	7
Adjusting the BM-1600 Brake Monitor	7
Adjusting Select-O-Stop.....	7

Operation

Select-O-Stop	8
Station 1/Both	8
Foot — Hand — Hand/Foot	8
Auto-Cycle	8
Auto-Return.....	8
Auto-Retrip.....	8
Auto-Form	8

Table of Contents

Foot Continuous.....	8
Emergency Stop	9
Top Stop Brake Indicator.....	9

Appendix A: Troubleshooting

Operational Display Messages	AA-1
External Error Messages	AA-2
Internal Error Messages.....	AA-4
Input / Output Designations	AA-5

Appendix B: Regulations and Guidelines

American National Standards Institute (ANSI).....	AB-1
Occupational Safety & Health Administration (OSHA).....	AB-2
Machine Control Reliability Requirements	AB-3
Safety Guidelines for Management.....	AB-3

Appendix C: Drawings

NEMA Control Wiring Diagrams.....	AC-1 to AC-7
-----------------------------------	--------------

The Press Brake Control Model 3400 is used to control Part Revolution Air Clutch Press Brakes. A dual microprocessor logic system is incorporated into the control logic which meets ANSI B11.1-1988 regulation guidelines for microprocessor based control systems. The control system will shut down if either redundant microprocessor logic system detects an internal or external fault. This configuration will safely shut down in the event of any single failure during the operation of the press.

A full four character alphanumeric diagnostics display scrolls messages in the event of a problem or failure. This display is used as an aid during troubleshooting.

Control Box Features

Depending on the selected options, the Press Brake Control box will contain a voltage transformer, dual microprocessor logic system, brake monitor, motor starter, light curtain interface, or main power disconnect.

Keylock Selector Switches

- 3 POS. Select-O-Stop
(off/on/slow form)
- 3 POS. Hand/Foot mode
(Foot/Hand/Both) (optional)
- 2 POS. Light Curtain
(off/on) (optional)
- 2 POS. Foot Continuous
(off/on) (optional)
- 2 POS. Operator Station
(Station 1/Both Stations) (optional)
- 2 POS. Auto-Form
(off/on) (optional)
- 2 POS. Auto-Retrip
(off/on) (optional)
- 2 POS. Auto-Cycle
(off/on) (optional)
- 2 POS. Auto-Return
(off/on) (optional)

Push Buttons

- Start - Used to allow press brake operation
- Stop - Used to stop press brake at any time (similar to Emergency Stop)

Indicator Lights

- System On
- Ground Fault - The white light is lit when the system is "ON," and the control circuit is properly grounded. If a ground fault occurs, the fuse will blow causing the light to go out and prevent the operation of the press.

CAUTION: The ground light must be lit at all times when the press is under power. If the light is off when the system is on, locate and correct the problem before operating the press.

- Top Stop Brake Indicator

Display Readouts

- Four character Alphanumeric diagnostics display
- Three digital display on Brake Monitor BM-1600 (optional)

Control Station Features

The Control Station will have two palm buttons and a red "Emergency Stop" button.

Options

Press Brake Control / Model 3400

BM-1600 Brake Monitor

The BM-1600 adds a time-based brake monitor, chain break detection, and tachometer to the press control panel. The encoder for the brake monitor comes installed inside the cam limit switch housing and does not need to be adjusted. The BM-1600 Brake Monitor has a three digit display to indicate SPM, stop time (mSEC), and diagnostic codes. The BM-1600 Brake Monitor has its own manual which includes information on proper setup and how to calculate the proper set-points.

NOTE: You must have access to the drive shaft on your press brake in order to use the BM-1600 Brake Monitor.

SuperLight VI Safety Light Curtain

Light curtains are infrared presence sensing devices that are mounted between the press operator and the point of operation. When placed the correct distance in front of the pinch point, the press will shut down when the operator tries to reach into the press and breaks the infrared beams of the light curtain. The system includes two self-contained pylons placed across the guarded zone and contain a redundant microprocessor system with a diagnostics display. Each system includes an installation manual that will instruct you on how to install and calculate the proper safety distance.

Zone Control (mat control)

If the area you are trying to guard has no defined pinch point (i.e., robotics equipment), you may want to guard the area with a safety mat. When activated, the control box will signal the press control to shut down. The control can be set for either automatic or manual reset. The safety mat system includes its own manual.

52-119 CPU / Input Board

The 52-119 can be configured as a Master or Slave board (one of each is required for operation)

Designator	Description
0 - 31	LED indicator for each input
J1	Jumpers installed to configure board as Master
J2	Jumpers installed to configure board as SLAVE
J3	Ribbon cable link between Master, Slave, and 52-120 power supply board
J4	Jumper Right 2 pins for Master, Left 2 pins for Slave
J5	Jumper Left 2 pins for Master, Right 2 pins for Slave
J6	Ribbon cable link between Master and Slave 52-119 boards
J7	Cable to Diagnostics Display
J8-J10	Opto Inputs 0-31 (Sourcing)
D65	+5vdc LED

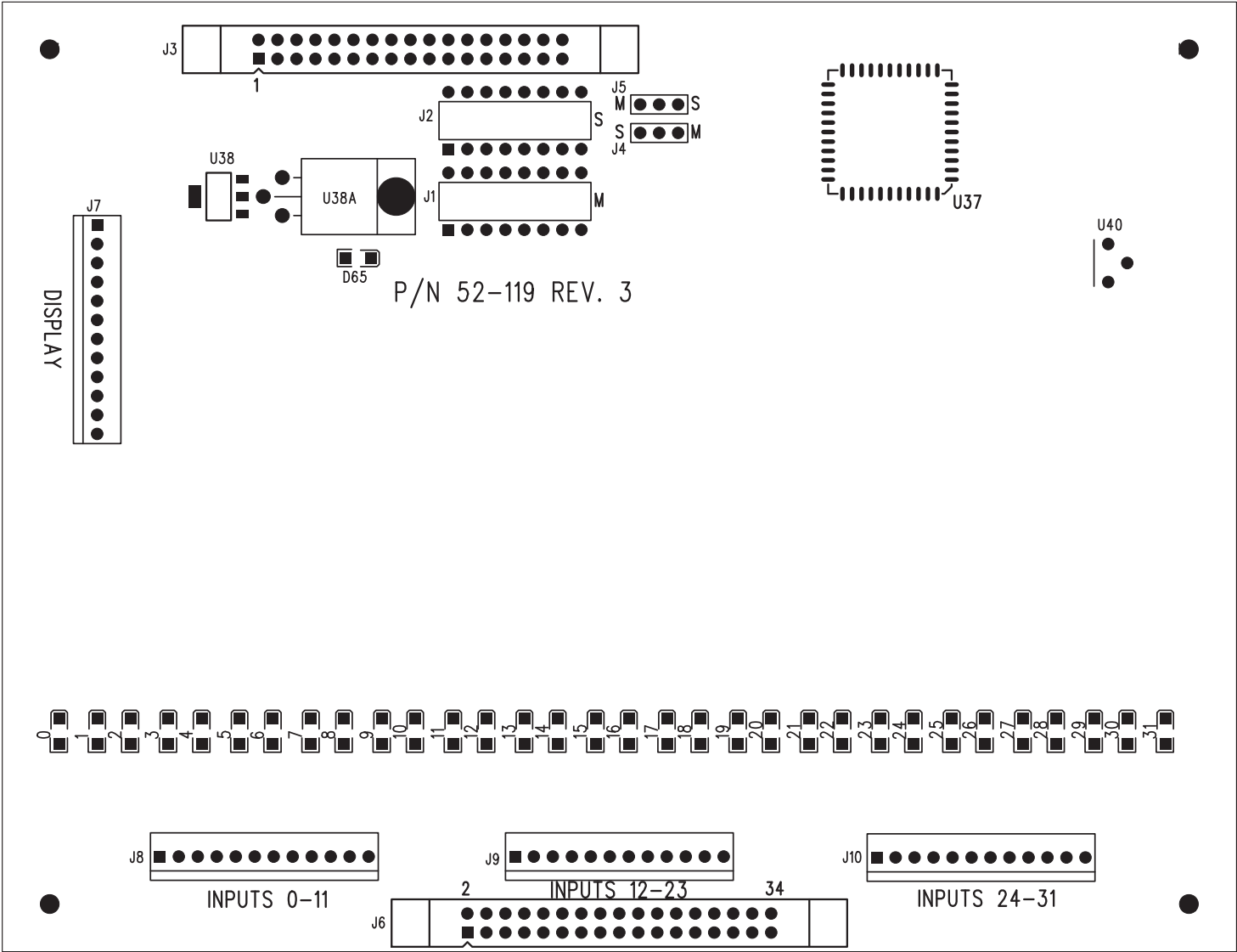

Installation

Press Brake Control / Model 3400

52-120 Power / Output Board

NOTE: All relay outputs are DRY contacts

Designator	Description
J1	Ribbon cable link between Power Supply 52-120, Master and Slave 51-119 boards
J2-1	Valve Output #1 K1(Both #1 and #2 must be used)
J2-2	Valve Output #2 K2
J2+24vdc	+24vdc output for use as common signal through switchgear back to the Opto Inputs.
J2-3	K7 Ground Fault Indicator when open
J2-4	K6 Light Curtain power when closed
J2-5	K5 Stroke Interrupted when closed
J2-6	K4 System ON when closed
J2-7	K3 Top Stop when closed
J2-COM	Common connection for K3-K7 Relay outputs
J2-G-N-L	Line Voltage Input (default is 120vac, optional 24vdc or 240vac) (24watts max)
F1	Fuse for Input Power (1A slow-blow) PN# 20-022
F2	Fuse for +24vdc J2-COM (1A slow-blow) PN# 20-018
A-B	Jumper configuration for selecting 120vac or 240vac
D2	LED for +24vdc
D51	LED for +5vdc
D53	LED for +12vdc
D11-D12	LED ON when Relays K1-K2 closed (active)
D13-D17	LED ON when Relays K3-K7 closed (active)

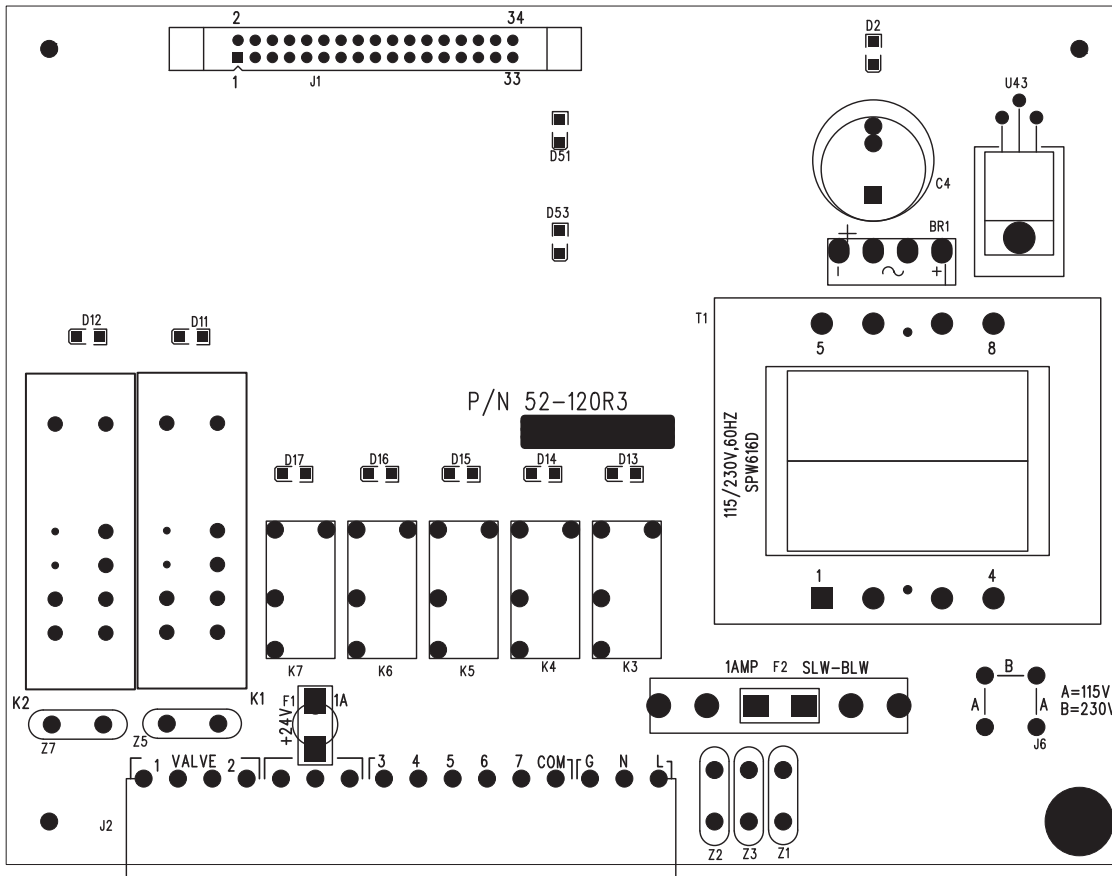

WARNING: The entire machine safety system must be tested at the start of every shift. Machine testing should include: (1) proper machine operation and stopping capability; and (2) verification of proper installation and settings of all point of operation guards and devices before the operation is released for production.

Control Box

Mount the Control Box at any convenient location on or near the press. If it is mounted on the press, you must shock mount the enclosure against vibration. If the operator's controls are located on the Enclosure, it should be mounted such that the operator has easy access to the Enclosure and can readily see the controls from in front of the press.

Electrical Wiring

Refer to Appendix C and interconnect the electrical components as shown. A separate earth ground conductor must be connected to the "G" terminal in the ground panel. This wire **must be** connected to an earth ground such as a grounding rod or a water pipe. The press should be grounded in a similar manner. **Do not** operate the press if this ground wire is not connected. Follow the National Electric Code, all state and local codes, and all applicable sections of OSHA when wiring the press.

Interlocks

On systems with air and power interlock function, additional interlocks may be wired into the system as shown in the wiring diagrams (refer to Appendix C).

Clutch Solenoid Valve

The clutch solenoid valve should be mounted as close as possible to the clutch cylinder or air clutch. The hose or pipe from the valve to the cylinder or air clutch should be as short as possible and at least the same size as the port on the cylinder or air clutch (refer to Appendix C).

Disconnect Switch

If the control enclosure is provided without a main power disconnect switch, a switch capable of being locked in the off position only should be provided on or near the press.

Limit Switches/Encoder Box

If you have access to the drive shaft on your press brake, you can use a rotary cam limit switch box. Otherwise you must use actuator arm switches.

Rotary Cam Switch Unit

- The Rotary Cam Switch (RCS) contains all the limit switches needed by the press control as well as a drive check switch used for chain break detection. The RCS must be linked to the press via a chain in a 1:1 configuration. Limit switches are driven via a rotary cam switch box with a built-in drive failure switch that signals the press in the event of a chain break. The limit switch mounting should be as close to the crank as possible.
- If the optional BM-1600 Brake Monitor was ordered with the press control, then the RCS assembly has the encoder needed by the BM-1600 Brake Monitor inside along with the limit switches. See the BM-1600 Brake Monitor manual for details. Wire up the BM-1600 Brake Monitor encoder cable to the RCS according to the BM-1600 Brake Monitor manual.

WARNING on ROTARY CAM INSTALLATION

Control Reliability requires that you must install any "Rotary Cam" box using the Spring Plate "Drive Check" (or "Chain Break") circuit properly attached to the Press Control input(s). You must mount/install the "Rotary Cam" box in such a way that the Spring Plate will open the "Drive Check" circuit should the linkage between Press and the "Rotary Cam" box fail.

If you cannot mount/install the "Rotary Cam" box using the Spring Plate "Drive Check" circuit, you **MUST** install a separate device that checks for MOTION of the press. The BM-1600 Brake Monitor can be installed to fulfill the requirement for MOTION detection. The BM-1600 would be wired into the STOP circuit of the Press Control. The Motion Detect setpoint must be set to the lowest value that allows the Press to operate.

Actuator Arm Limit Switch

If you do not have access to the drive shaft on your press brake, you must mount actuator arm limit switches on the press brake (Refer to Appendix C).

Installation

Press Brake Control / Model 3400

Operator's Station

The operator's control station, or palm buttons if supplied separately, should be mounted on the press such that the operator can easily reach the controls. They should be mounted far enough away from the point of operation, or other hazard, such that the operator is protected against accidental contact with the point of operation (see "ANSI Standards" in Appendix B).

Additionally, both palm buttons should be mounted such that the operator is required to use both hands to operate the press. **They should be far enough apart (minimum of 25") such that a hand and an elbow of the same arm nor any other part of the body except the other hand may be used to operate the press.** Both palm buttons must be wired to their correct inputs. They **must not** be wired any other way. The press control contains the anti-tie-down programming needed to protect the operator from running the press with one hand. Each operator or his helper must have his own set of palm buttons to operate the press.

Emergency Stop Buttons

Emergency stop palm buttons should be located on the press such that the operator (or helper) at any one time during the operation of the press may easily reach the emergency stop button. This button is normally located on the operator's station (run bar).

Adjusting the Limit Switches

Refer to the timing chart as well as control wiring diagrams provided.

- Limit switch LS1 is used as the top stopping means. It should be opened just before top dead center and remain open just long enough to bring the ram to rest. On some presses it may be necessary to increase this time slightly to compensate for heating effects or slippage of the breaking mechanism. However, it is necessary to keep the open time as short as possible.
- Limit switch LS2 must close 10° to 20° before LS1 opens and remain closed to 10° after LS1 has closed. This time is governed by the speed of the press. The faster the press, the greater the time. If the overlap time (the time when both switches are closed) is set too short, the press will stall occasionally, indicating that the time should be increased.
- Limit switch LS3 is used to initiate an automatic stop (Select-o-Stop) during the down stroke of the ram. LS3 is normally set to stop the ram 1/4" or less above the material.
- Limit switch LS4 is used to bypass the light curtain or allow the transfer from hand to foot operation depending on what type of control has been provided (see Operation section).
- Limit switch LS5 is used to provide the Auto Return function and should signal the bottom of the stroke. LS5 should close just before the bottom of the stroke and remain closed long enough to be detected.

WARNING on LINEAR LIMIT SWITCH INSTALLATION

Control Reliability requires that you must never actuate LIMIT SWITCHES from the same actuating device (i.e. same Strike Plate or mechanical cam). All LIMIT SWITCHES cross check each other and so much be fully independent from each other. If the same actuating device is used between multiple LIMIT SWITCHES, then a method must be used to check for failure of the actuating device that meets Control Reliability standards.

Adjusting the BM-1600 Brake Monitor

Locate the installation manual for the BM-1600 Brake Monitor that came with the press control. If the press came with a Rotary Cam Switch (RCS) assembly then place the encoder needed by the BM-1600 Brake Monitor inside along with the limit switches. If no RCS was ordered with the press, a separate encoder box is provided. Wire the BM-1600 Brake Monitor encoder cable to the RCS or encoder box according to the BM-1600 Brake Monitor manual. Now, you must use the "90° From Top Stop" feature of the BM-1600 Brake Monitor to compute a worst case stop time for your press. Follow the instruction manual on selecting the correct stopping / warning times for your press.

Adjusting Select-o-Stop

To activate this feature, turn the keyswitch to "ON" and adjust the calibrated switch actuator which is located on the ram at the side of the brake. The calibrated switch actuator will activate LS3 which, in turn, will stop the ram in the down stroke. The calibrated switch actuator should be set so the stopping point of the ram is 1/4" or less of an opening at the point of operation.

Operation

Press Brake Control / Model 3400

Select-O-Stop

The *Select-O-Stop* function automatically stops the ram at a predetermined point in the downstroke, usually 1/4" above the point of operation, to make adjustments to the work piece before the final operation takes place.

Slow-form is part of Select-O-Stop and when active the press will move at full speed with the clutch fully engaged until Select-O-Stop is reached, then stop. When you reactivate the press, the slow form cylinder will control the engagement of the clutch as long as you keep the press active. When you reach top stop, the slow form cylinder will be by-passed until Select-O-Stop is reached again.

Station 1/Both

Only *Station 1* palm buttons and/or foot switch must be active to start the press.

Both station 1 and 2 palm buttons and/or foot switches must all be activated to start the press. The foot continuous mode will not work when the keyswitch is in the Both position.

NOTE: Both operators must be protected by a light curtain or some other means to ensure safety.

Foot — Hand — Hand/Foot

In the *Foot* position, the foot switch will perform all operations. The Station 1/Both keyswitch determines if both foot switches must be active. In the *Hand* position, the palm buttons will perform all operations. In the *Hand/Foot* position, the press will operate with the palm buttons during the down stroke. The ram will stop at the position selected for Select-O-Stop. At that point, the foot switch will become active for the up stroke of the ram and the ram will stop on top returning to hand mode.

Auto-Cycle

The *Auto-Cycle* option is only active in Select-O-Stop with the light curtain turned on. This will allow the press to operate from the pinch point through the top of the stroke and will stop again at the Select-O-Stop initiating point. The light guard is muted out during the up-stroke of the press and active during the down-stroke.

Auto-Return

The *Auto-Return* option will cycle the ram from the bottom to the top of the stroke and stop without the operator having to maintain contact on either the foot switch or palm buttons. This uses LS5 to signal the bottom of the stroke.

Auto-Retrip

When the Select-O-Stop function has been turned on, the press will automatically stop at a preset point, which is normally set at a 1/4" opening or less. After a brief pause, the press will then continue the rest of the cycle. If you release the pedal before it starts up again, the *Auto-Retrip* feature turns off until you come back around to Select-O-Stop.

Auto-Form

Auto-Form must be used in conjunction with the Select-O-Stop Slow-Form setting. While controlling the forming speed of a piece part it sometimes is necessary to fully engage the clutch, just prior to the bottom of the stroke, to obtain a desired radius with the die being used. *Auto-Form* will bypass the slow form cylinder at that point, allowing full engagement of the clutch and preventing the possibility of jamming or stalling at the bottom of the stroke. The bypass will occur when the ram reaches LS5.

Foot Continuous

The *Foot Continuous* mode will cycle the press continuously as long as the operator maintains foot pedal contact and the light guard beams remain unbroken. If the press stops due to interference with the light beams, the operator must remove his/her foot from the pedal and reinitiate.

NOTE: Light curtain can not be bypassed while in this mode.

HAND/FOOT keyswitch	FOOT
LIGHT GUARD keyswitch	ON
FOOT CONTINUOUS keyswitch	ON
AUTO-CYCLE keyswitch	OFF
AUTO-RETURN keyswitch	OFF
SELECT-O-STOP keyswitch	OFF
STATION 1/BOTH	STA 1

Emergency Stop

The large red mushroom head “Emergency Stop” button is located on the operators station (run bar). When the *Emergency Stop* button is pressed, the slide will stop immediately and power to the main drive motor will be shut off.

Top Stop Brake Indicator

The *Top Stop Brake Monitor* is designed to indicate increased stopping time at the top of the stroke. Limit Switch LS2 is to be set to open at the top of the stroke when the angle or degrees specified by the manufacturer is exceeded.

Example: If the press control is set so the press stops at 0 degrees, it is up to the user to determine how much additional over travel will be allowed before the Top Stop indicator will be activated. If the user sets LS2 to open at two, the system will lock out if the press stops at three or greater. When this happens, the brake **must be** adjusted or repaired. **Do not** re-adjust LS2 to prevent lockout unless stopping time is measured and safety distance is adjusted.

Appendix A:

Troubleshooting

Press Brake Control / Model 3400

If the press will not operate, check the following:

- Check the Diagnostics Display on the front control panel. Any discrepancy between the redundant control logic system or a fault within one of the systems will force a message to scroll across the display. The message should be fairly self explanatory, however, a detailed description can be found under either “Operational Display Messages” or “External Error Messages” in this section.
- With the system energized and the “Start” button pushed, both “System On” and “Ground” indicator lights should be lit. If not, check the Stop circuit. Input #1 LED should be on.

- With both lights on (see above) and the ram at the top of the stroke, the following LED’s on the controller should be lit:

INPUT	1 =	STOP
	2 =	LS1
	3 =	LS2
	10 =	SELECT-O-STOP
	24 =	ROTARY CHAIN BREAK SWITCH
	23 =	PRESSURE SWITCH 1
	22 =	EMERGENCY STOP
OUTPUT	0 =	SYSTEM ON
	1 =	GND IND.

- When setting limit switches, make sure that LS2 closes before LS1 opens. Also, LS1 should close before LS2 opens. If the ram stops before the top of the stroke, advance LS1 and LS2. Conversely, if the ram stops after the top of the stroke, retard both LS1 and LS2.
- The built-in Top Stop Brake Indicator is designed to indicate increased stopping time at the top of the stroke and is position based only. The BM-1600 Brake Monitor is time based and shows stopping times anywhere during the stroke. Limit Switch LS2 is to be set to open at the top of the stroke when the angle or degrees specified by the manufacturer is exceeded. For example, if the press control is set so the press stops at 0°, it is up to the user to determine how much additional over travel will be allowed before the Top Stop Indicator will be activated. If the user sets LS2 to open at 2°, the system will lock out if the press stops at 3° or greater. When this happens, the brake **must** be adjusted or repaired. **Do not readjust LS2 to prevent lockout unless stopping time is remeasured and safety distance is adjusted.**

- To clear an error message from the diagnostics display, press “Stop.” The message will reappear if the error was not corrected.

Operational Display Messages

Messages that appear on the display, but no fault has occurred.

MESSAGE: OFF
PURPOSE: Indicates that the computers are powered up and operating properly awaiting the “Start” button.

MESSAGE: RDY
PURPOSE: Indicates that the “Start” button was pushed and no optional features are active.

MESSAGE: SOS
PURPOSE: Select-O-Stop keyswitch is in the “ON” position

MESSAGE: SFRM
PURPOSE: The ram has reached Select-O-Stop with “Slow Form” turned on

MESSAGE: FCNT
PURPOSE: Foot Continuous mode has been selected and the light guard is on and Select-O-Stop is off.

MESSAGE: ACYL
PURPOSE: Auto-Cycle mode is turned on and light guard is on.

MESSAGE: ARTN
PURPOSE: Auto-Return mode is turned on.

MESSAGE: ATRP
PURPOSE: Auto-Retrip mode is turned on and Select-O-Stop is also on.

MESSAGE: AFRM
PURPOSE: Auto-Form mode is turned on and slow-form is on.

MESSAGE: ESTP
PURPOSE: Indicates that the “Emergency Stop” button is being pushed. The display will return to display “Off” when you release this button. You can use this button to clear error messages from the display.

Appendix A: Troubleshooting Press Brake Control / Model 3400

MESSAGE: STOP
PURPOSE: Indicates that the “Stop” button is being pushed. The display will return to display “Off” when you release this button. You can use this button to clear error messages from the display.

External Error Messages

Messages that indicate an error occurred outside the control box.

MESSAGE: PLM1, PLM2
PURPOSE: Indicates that only one of the two palm buttons at a particular station (1,2) had activated within 1/4 second and that the other palm button either was activated too late or never. There can be up to two palm button stations.

SOLUTION: Try turning on only one palm button station and activating both palm buttons simultaneously. Check the palm button LED’s on the press control itself to see if they are both activating (see Appendix C).

MESSAGE: CHAIN BREAK
PURPOSE: Rotary Cam Drive switch opened up indicating the chain driving the limit switches is broken or wiring is bad.

SOLUTION: Check this input to see if LED is on.
a) If LED is on then:
1) The chain break switch is intermittantly bad; or
2) PLC board is bad and must be replaced.
b) If LED is off then either the chain is broken or the switch is bad.

MESSAGE: PRESSURE SWITCH FAULT
PURPOSE: Air pressure going to the clutch is either low or high

SOLUTION: Check this input to see if LED is on.
a) If LED is on then:
1) The chain break switch is intermittantly bad; or
2) PLC board is bad and must be replaced.
b) If LED is off then check air pressure and valve.

MESSAGE: INPUT(S) TOO NOISY
PURPOSE: All 24VDC inputs (up to 32) are optically coupled to the controller. The controller digitally filters out any noise caused by external devices (i.e., motors, solenoids, etc.) that may get inside the control box via one of the 24VDC inputs. However, there may be a time when there is too much noise to allow safe operation of the press. In this case, the press will shut down.

SOLUTION:
a) Check for loose wires on all terminal strips, including the controller boards.
b) Check that the control box is connected to a good EARTH ground.
c) Try and determine when this error message occurs during the stroke and if any specific valve, motor, solenoid, switch, etc. is switched on or off at that moment in time. You may need to place a MOV across the input of the offending device to quiet it down.

MESSAGE: LS1L
PURPOSE: Limit switch 1 is stuck open (off) and never closed (on). LS1 should open up just after LS2 closes but close again to signal top stop.

SOLUTION:
a) LS1 may be open for too large an angle.
b) LS2 may be closed for too short an angle (see Alignment and Setup section).
c) Limit switch is broken or wiring is open.
d) Press was started from a position other than top stop
To clear this error you must press the “Stop” button.

MESSAGE: LS1H
PURPOSE: Limit switch 1 is stuck closed (on) and never opened (off). LS1 should have opened up while LS2 was closed.

SOLUTION:
a) LS1 may be opened for too small an angle to be sensed (see Alignment and Setup section).
b) Limit switch is broken or wiring is shorted.
c) Press was started from a position other than top stop
To clear this error you must press the “Stop” button.

Appendix A:

Troubleshooting

Press Brake Control / Model 3400

MESSAGE: LS2L
PURPOSE: Limit switch 2 is stuck open (off) and never closed (on) during the stroke. This will cause the “Top Stop Brake Monitor” light to go on.
SOLUTION: a) LS2 may be closed for too small an angle to be sensed (see Alignment and Setup section).
b) Limit switch is broken or wiring is open.
To clear this error you must press the “Stop” button.

MESSAGE: LS2H
PURPOSE: Limit switch 2 is stuck closed (on) and never opened (off) during the stroke. It should be open before it reaches LS3.
SOLUTION: a) Limit switch may be set to close at the wrong time (see Alignment and Setup section).
b) Limit switch is broken or wiring is shorted.
c) Press was started from a position other than top stop
To clear this error you must press the “Stop” button.

MESSAGE: LS3L
PURPOSE: Limit switch 3 is stuck open (off) and never closed (on) during the stroke.
SOLUTION: a) LS3 may be closed for too small an angle to be sensed (see Alignment and Setup section).
b) Limit switch is broken or wiring is open.
c) Press was started from a position other than top stop
To clear this error you must press the “Stop” button.

MESSAGE: LS3H
PURPOSE: Limit switch 3 is stuck closed (on) and never opened (off) during the stroke. It should be open before it reaches LS2 closed.
SOLUTION: a) Limit switch may be set to close at the wrong time (see Alignment and Setup section).
b) Limit switch is broken or wiring is shorted.
To clear this error you must press the “Stop” button.

MESSAGE: LS4L
PURPOSE: Limit switch 4 is stuck open (off) and never closed (on) during the stroke.
SOLUTION: a) LS4 may be closed for too small an angle to be sensed (see Alignment and Setup section).
b) Limit switch is broken or wiring is open.
c) Press was started from a position other than top stop
To clear this error you must press the “Stop” button.

MESSAGE: LS4H
PURPOSE: Limit switch 4 is stuck closed (on) and never opened (off) during the stroke. It should be open before it reaches LS2 closed.
SOLUTION: a) Limit switch may be set to close at the wrong time (see Alignment and Setup section).
b) Limit switch is broken or wiring is shorted.
To clear this error you must press the “Stop” button.

MESSAGE: LS5L
PURPOSE: Limit switch 5 is stuck open (off) and never closed (on) during the stroke.
SOLUTION: a) LS5 may be closed for too small an angle to be sensed (see Alignment and Setup section).
b) Limit switch is broken or wiring is open.
c) Press was started from a position other than top stop
To clear this error you must press the “Stop” button.

MESSAGE: LS5H
PURPOSE: Limit switch 5 is stuck closed (on) and never opened (off) during the stroke. It should be open before it reaches LS2 closed.
SOLUTION: a) Limit switch may be set to close at the wrong time (see Alignment and Setup section).
b) Limit switch is broken or wiring is shorted.
To clear this error you must press the “Stop” button.

Appendix A: Troubleshooting Press Brake Control / Model 3400

Internal Error Messages

Messages that indicate a fault in the controller itself or an incorrect setting.

MESSAGE: RST
PURPOSE: Indicates the Master has reset itself and the Slave has not indicated its presence.
SOLUTION: Power down the controller for 30 seconds and try to restart the controller again.
a) Check the ribbon cable and the microprocessor chips. They may have come loose from their sockets.
b) May be a bad Slave chip.

MESSAGE: SLAVE PROGRAM DOESN'T MATCH MASTER
PURPOSE: The program code running on the Slave board is not the same program version running on the Master board.
SOLUTION: Check Master program version number displayed at power up and compare it with what's written on the Master and Slave chips. Reset power and try again. If the problem persists, the slave chip may be incorrect or bad. Call manufacturer to determine which number is the correct one.

MESSAGE: VER 1.00
PURPOSE: This message does not indicate an error. It is used to indicate the software version number. The number to the left indicates the type of software. The number to the right indicates the revision number. As the version number is displayed, the system is self checking.

MESSAGE: MASTER ON, SLAVE OFF, CHECK INPUT #
PURPOSE: The top board (Master) sees an input signal that the bottom board (Slave) does not.
SOLUTION: Check the LED's on each board corresponding to the input number specified in the error message.
a) If the Master LED in "On" and the Slave LED is "Off" then the problem is either in the wiring going to the Slave or the opto-coupled input on the Slave is bad and the Slave board must be replaced.

b) If both Master and Slave LED's are on, then the problem is with the Slave board circuitry. The Slave board must be replaced.
MESSAGE: SLAVE ON, MASTER OFF, CHECK INPUT #
PURPOSE: The bottom board (Slave) sees an input signal that the top board (Master) does not.
SOLUTION: Check the LED's on each board corresponding to the input number specified in the error message.
a) If the Slave LED in "On" and the Slave LED is "Off" then the problem is either in the wiring going to the Master or the opto-coupled input on the Master is bad and the Master board must be replaced.
b) If both Master and Slave LED's are on, then the problem is with the Master board circuitry. The Master board must be replaced.

MESSAGE: LIGHT GUARD MUST BE ON
PURPOSE: a) Auto-Cycle is on but the light guard keyswitch is off.
b) Foot Continuous is on but the light guard keyswitch is off.
SOLUTION: Turn light guard keyswitch on.

MESSAGE: SOS MUST BE ON
PURPOSE: Auto-Retrip is on but the Select-O-Stop keyswitch is off.
SOLUTION: Turn Select-O-Stop keyswitch on.

MESSAGE: SOS MUST BE OFF
PURPOSE: Foot Continuous is on and the Select-O-Stop keyswitch is on.
SOLUTION: Turn Select-O-Stop keyswitch off.

MESSAGE: SLOW FORM MUST BE ON
PURPOSE: Auto-Form is on, but Slow-Form is off.
SOLUTION: Turn Select-O-Stop keyswitch to Slow-Form.

MESSAGE: RELAY 1 OR 2 IS ON, SHOULD BE OFF
PURPOSE: There are two safety relays (1 and 2) that are used to stop/start the press. The Master has detected that one or both relay's remained in the closed position when the relays were de-energized.
SOLUTION: a) Check the contacts on Relay #1 for pitting, scoring, or discoloration.

Appendix A:

Troubleshooting

Press Brake Control / Model 3400

b) Check for failed solder joint on PCB. PCB will need to be repaired or replaced.

MESSAGE: RELAY 1 OR 2 IS OFF, SHOULD BE ON

PURPOSE: The Master has detected that Relay #1 did not turn on when energized.

SOLUTION: Bottom board must be examined for relay failure.

MESSAGE: SLAVE RELAY 1 OR 2 IS ON, SHOULD BE OFF

PURPOSE: The Slave has detected that Relay #1 remained in the closed position when the relay was de-energized.

SOLUTION: a) Check the contacts on Relay #1 for pitting, scoring, or discoloration.
b) Check for failed solder joint on PCB. PCB will need to be repaired or replaced.

MESSAGE: SLAVE RELAY 1 OR 2 IS OFF, SHOULD BE ON

PURPOSE: The Slave has detected that Relay #1 did not turn on when energized.

SOLUTION: Slave board must be examined for failure.

MESSAGE: MASTER INTERNAL RAM BAD

PURPOSE: Ram failed during the power up test.

SOLUTION: Power down the press control system. If the error occurs again when powered up, then the Master microprocessor on the top board must be replaced.

MESSAGE: SLAVE INTERNAL RAM BAD

PURPOSE: Ram failed during the power up test.

SOLUTION: Power down the press control system. If the error occurs again when powered up, then the Slave microprocessor on the lower board must be replaced.

MESSAGE: CANNOT TALK TO SLAVE

PURPOSE: Master microprocessor on the top board cannot talk to the Slave microprocessor on the bottom board.

SOLUTION: Check the ribbon cable for proper visual termination. The PLC boards must both be examined and repaired.

MESSAGE: CHKSUM ERROR WITH SLAVE

PURPOSE: Data sent from the Slave computer to Master computer was corrupted.

SOLUTION: One the of two PLC boards may have reset due to noise causing them to fall out of synchronization with each other. Reset the power and try again. If it continues to happen, check for loose wiring and/or improper voltage levels on the power lines, or power supply lines. Also, check for noise coming from bad relay contacts nearby.

Input/Output Designations

The following is a list of inputs and outputs as wired to the dual microprocessor logic system:

Numbers start out from left side, looking at the terminal strip from the front. All inputs use output #6 as their common.

INPUTS

0	start
1	STOP
2	LS1
3	LS2
4	LS3
5	LS4
6	FOOT MODE
7	PALM BUTTON 1
8	PALM BUTTON 2
9	FOOT SWITCH 1
10	SELECT-O-STOP
11	AUTO-RETURN KEYSWITCH
12	HAND/FOOT MODE
13	LIGHT GUARD KEYSWITCH
14	LIGHT GUARD CONTACTS
15	SLOW FORM
16	AUTO-CYCLE
17	FOOT CONTINUOUS
18	STATION 1/BOTH
19	PALM BUTTON 3
20	PALM BUTTON 4
21	FOOT SWITCH 2
22	EMERGENCY STOP
23	PRESSURE SWITCH
24	CHAIN BREAK
25	AUTO-FORM
26	AUTO-RETRIP
27	LS5
28	not used
29	not used
30	not used
31	not used

OUTPUT

- 1 MAIN VALVE #1
- 2 COMM #1
- 3 MAIN VALVE #2
- 4 COMM #3
- 5 nc
- 6 19.8 VDC COMM
- 7 nc
- 8 SYSTEM ON
- 9 LT. GUARD PWR
- 10 FEED SOLENOID
- 11 GROUND IND.
- 12 BRAKE MONITOR
- 13 COMM #8-#12
- 14 EARTH GROUND
- 15 NEUTRAL
- 16 LINE (+120VAC)

Appendix B:

Regulations and Guidelines

Press Brake Control / Model 3400

American National Standards Institute (ANSI)

B11.1-1988

6.3.2 Presence-sensing Point of Operation Devices

A presence-sensing point-of-operation device, if used, shall protect the operator and others, and shall be interfaced with the control circuit to prevent or stop slide motion if the operator's hand or other body part is within the sensing field of the device during the closing portion of the stroke. In addition:

- (1) Presence-sensing devices shall not be used for safeguarding the point of operation on presses using full-revolution clutches.
- (2) When the sensing field has been interrupted, use of the normal press stroke initiating means shall be required after clearing the sensing field to resume press operation.
- (3) Muting (bypassing of the protective function) of the device shall be permitted after the hazardous portion of the press stroke has been completed. Muting of the device shall be accomplished in such a manner that no single component failure shall prevent the normal stop command but shall prevent subsequent press strokes until the failure is corrected.
- (4) The device shall have an identifiable minimum object sensitivity so that an obstruction of an equal or greater size will be detected anywhere within the sensing field regardless of the plane of intrusion.
- (5) The device shall have a maximum response time which shall not be affected by object sensitivity adjustments or environmental changes.
- (6) The devices which require adjustments to accommodate variations in ambient or operating conditions or which incorporate channel blanking or floating window features shall be designed so that the adjustments or features are capable of being supervised by the employer.
- (7) The presence-sensing device shall be provided with a means that visibly indicates when it is and is not in use and functioning properly. The device shall also indicate which sections, if any, have been blanked out.
- (8) The device shall not fail to respond to the presence of the operator's or other's hand or body part due to the presence of a reflective object or work piece.
- (9) The device shall be designed and constructed so that any single component failure, including output devices, shall not prevent the normal STOP command from being sent to the press, but shall prevent operation of the press stroke until the failure has been corrected. In the event of a power failure to the device, it shall initiate a STOP command to the press-control system.
- (10) The device and the press-control system shall be interfaced so that the device's STOP command shall initiate stopping action during the closing portion of the press stroke. The interface shall be designed to ensure that a single component failure within the interface of the control system shall not prevent the normal STOP command from being sent to the press, but shall prevent operation of the press stroke until the failure has been corrected.
- (11) The device's sensitivity to intrusion shall not be adversely affected by changing conditions around the press.
- (12) The effective sensing field of the device shall be located at a distance from the nearest point-of-operation hazard so that the operator or others cannot reach into the point of operation with a hand or other body part before cessation of motion during the closing portion of the stroke.
- (13) The device shall not be affected by ambient light or by light-source decay so that the increase in response time or object sensitivity is greater than the value used to calculate the safety distance.
- (14) All areas of entry to the point of operation not protected by the presence-sensing device shall be otherwise safeguarded.
- (15) When a device is used on a press in a single-stroke mode and when the protection of the operator is dependent upon the stopping action of the press, a stopping performance monitor shall be required.

Appendix B: Regulations and Guidelines

Press Brake Control / Model 3400

B11.19-1990

6.3.5 Two-Hand Control Device

- (3) Each operator hand control shall be located at a distance from the point of operation so that the operator cannot release either hand control and reach into the point of operation prior to die closure or prior to cessation of slide motion during the closing portion of the stroke.

Below is the formula for calculating the safety distance of a light curtain or palm buttons. The machine stop time should be measured with the machine running at its fastest speed with its heaviest die or tooling and the stop time being measured at the 90° position in the downstroke. The following formula should be used when calculating the safety distance:

$$DS = K \times (TS + TC + Tr + Tbm)$$

DS = Minimum safety distance between the device and the nearest point of operation hazard (in inches).

K = Hand speed constant. This value has been determined by various studies and although these studies indicate speeds of 63 in/sec to over 100 in/sec, they are not conclusive determinations. The employer should determine this value by considering all factors, including physical ability of the operator.

TS = Stop time of the machine tool measured at the final control element.

TC = Response time of the control system. NOTE: TS and TC are usually measured by a stop time measurement device.

Tr = Response time of the presence-sensing device and its interface, if any, as stated by the manufacturer or measured by the employer.

Tbm = Additional time allowed for the brake monitor to compensate for variations in normal stopping time.

Occupational Safety & Health
Administration (OSHA)

1910.217 (C) (3) (iii)

Safeguarding the Point of Operation

- (iii) A presence sensing point of operation device shall protect the operator as provided in paragraph (c) (3) (i) (a) of this section, and shall be interlocked into the control circuit to prevent or stop slide motion if the operator's hand or other part of his

body is within the sensing field of the device during the downstroke of the press slide.

- (a) The device may not be used on machines using full revolution clutches.
- (b) The device may not be used as a tripping means to initiate slide motion.
- (c) The device shall not be constructed so that a failure within the system does not prevent the normal stopping action from being applied to the press when required, but does prevent the initiation of a successive stroke until the failure is corrected. The failure shall be indicated by the system.
- (d) Muting (bypassing of the protective function) of such device, during the upstroke of the press slide, is permitted for the purpose of parts ejection, circuit checking, and feeding.
- (e) Refer to ANSI B11.19-1990 above for calculating safety light curtain distance from the point of operation.
- (f) Guards shall be used to protect all areas of entry to the point of operation not protected by the presence sensing device.

1910.217 (C) (3) (iii)

Additional requirements for safeguarding

Where the operator feeds or removes parts by placing one or both hands in the point of operation, and a two hand control, presence sensing device or Type B gate or movable barrier (on a part revolution clutch), is used for safeguarding:

- (i) The employer shall use a control system and a brake monitor which comply with paragraphs (b) (13) and (14) of this section.
- (e) Inspection, maintenance, and modification of presses-
 - (i) It shall be the responsibility of the employer to establish and follow a program of periodic and regular inspections of his power presses to insure that all their parts, auxiliary equipment, and safeguards are in a safe operating condition and adjustment. The employer shall maintain records of these inspections and maintenance work performed.

Appendix B:

Regulations and Guidelines

Press Brake Control / Model 3400

1910.212

General requirements for all machines (covers press brakes, hydraulic and pneumatic machines not covered by mechanical power press standards).

- (a) Machine guarding - (1) Types of guarding. One or more methods of machine guarding shall be provided to protect the operator and other employees in the machine area from hazards such as those created by point of operation in going nip points, rotation parts, flying chips and sparks. Examples of guarding methods are: barrier guards, two-handed tripping devices, electronic safety devices, etc.

NOTE: These are only partial reprints, refer to your Federal Register for total construction, control reliability, and machine guarding requirements for the subject machine being guarded for all applicable OSHA Standards.

Machine Control Reliability Requirements

Control Reliability:

"...control circuits shall be designed and constructed so that a single failure or fault within the system does not prevent the normal stopping action from being applied to the press when required, or does not create an unintended stroking action, but does prevent initiation of a successive stroke until the failure is corrected." (ANSI B11.1-1988)

"...control shall be designed to prevent initiation of a stroke signal in the event that a failure occurs within the press control." (ANSI B11.2-1982)

"Robots shall be designed and constructed so that any single, reasonably foreseeable failure will not cause hazardous motion of the robot." (ANSI/RIA R15.06-1991)

"...control circuits shall incorporate features to minimize the possibility of an unintended stroke in the event of the failure of the control component to function properly, including relays, limit switches, and static output circuits." (ANSI B11.1-1982)

"...control system shall be constructed so that a failure within the system does not prevent the normal stopping action from being applied to the press when required, but does prevent initiation of a successive stroke until the failure is corrected." (ANSI B11.1-1982)

"...the control system shall be constructed so that a failure within the system does not prevent the normal stopping action from being applied to the press when required, but does prevent initiation of a successive stroke until the failure is corrected." (OSHA CFR 1910.217, 1988)

Safety Guidelines for Management

Operational Safety

1. Appoint a Safety Coordinator to be responsible for safety regulations, requirements, and suggestions. He must review and investigate all accidents and "close calls."
2. Establish and issue safety rules. Inform each employee of his responsibilities. Make sure he understands them and knows what is expected of him.
3. A thorough review and an early inspection must be made of existing presses, dies, and point of operation guarding to attain the degree of responsibility required by ANSI B11.1-1988 Safety Standards and Federal State laws. Review what mandatory modifications are necessary.
4. Equipment that is no longer safe and cannot be economically upgraded should be destroyed.
5. Never allow persons legally under age to operate or assist in the operation of machinery.
6. All personnel must be properly trained to eliminate accidents and injuries.
7. Regardless of the operator's experience, education or language barrier, it is the responsibility of the supervisor to give him a thorough explanation with each new job assignment.
8. No employee should be given a work assignment that he does not fully understand. Only properly instructed and thoroughly trained personnel should be assigned to work on or with any machine.
9. It shall be the responsibility of the employer to provide an adequate, clean, safe, and uncluttered work area around each machine.
10. If a malfunction is reported, stop the machine immediately, correct the problem, then resume production.

Appendix B: Regulations and Guidelines Press Brake Control / Model 3400

11. Investigate all accidents and close calls. Analyze the reason for occurrence. Take action to prevent recurrences. Keep records of the investigation and preventative steps that were taken.
12. Only employees who understand the machines' operation and safety requirements and who are able to communicate this knowledge should be given the responsibility of instructing and training others to perform as operators.
13. Management must decide that personnel protective safety equipment is required to perform each job safely. Items such as safety glasses, shoes, gloves, helmets, hand pads, spats, protective sleeves, and material handling equipment are common in the metal working industry. If noise levels are excessive, protective head sets and ear muffs are recommended.
14. When designing point of operation guarding, the manufacturing process should be weighed heavily in favor of operational safety.
15. Establish safe and convenient material handling methods and procedures.
16. Post in convenient areas the names, addresses, and phone numbers of physicians and hospitals, and members of the organization who are to be called in case of emergency.
17. All equipment must be electrically connected according to the National Electric Code and be consistent with other accepted practices.
18. Provide adequate and proper fire protection equipment.

Power Press Guarding

1. Press manufacturers do not know and cannot foresee the magnitude of potential applications of power presses. Therefore, only the press user can determine the type of guards that have to be used in order to perform the job safely. It is the responsibility of the user management to make certain that point of operation guarding and other necessary safety devices are installed. The press should be guarded in such a manner that it is impossible for the operators to place their hands or any other part of the body in the die area.
2. The press user should become thoroughly acquainted with the safety devices commonly employed in power press operations.

3. Feeding devices are strongly recommended since they remove the operator from the die area and, therefore, allow more effective utilization of guards and safety devices.
4. Do not release a press for production before installing and testing all guards and covers.
5. Make frequent evaluation checks of all guarding and devices while the press is running. Correct all unsafe findings immediately.

Power Press Care Through Inspection and Maintenance

1. All maintenance and inspection personnel should be specifically instructed and must understand proper maintenance and inspection procedures contained in this manual.
2. Set up a daily, weekly, and monthly press inspection program. Use a checklist and verify that the job is done correctly.
3. Establish a preventative maintenance program. Records of all maintenance work performed must be kept.
4. Since all equipment has a limited life, quality maintenance personnel are required to obtain maximum usage of your equipment.
5. Releasing a power press for production following maintenance should be the responsibility of a qualified individual assigned by management.
6. To maintain the original level of press reliability, careful inspection of mechanical, electrical, and pneumatic areas must be made. This may give an advance warning of a hazard which then can be corrected to prevent possible injuries and damage.

Safety Enforcement

In order to have an effective safety program, management at all levels must enforce every safety rule and regulation. Strong disciplinary measures are sometimes required. They should consist of a warning, written reprimand, work suspension, transfer, demotion, or possibly a dismissal. All infractions must be reported and recorded. Once an infraction is noted, it shows that an unsafe practice or condition has existed. This may be the result of poor planning or improper training and instructing. The reason for the infraction should be analyzed in order to take corrective action.

Appendix B: Regulations and Guidelines Press Brake Control / Model 3400

Supervisor Training

It should be the responsibility of management to instruct their supervisors on safety, giving job instructions, supervising operators, determining accident causes, and building safety attitudes among the machine operators. Accidents can occur due to inadequate training of supervisors.

Operator Training

It shall be the responsibility of management to insure proper training of operators. A specific training program should be instituted to instruct the operator in safety, proper usage of the equipment, and correct operational procedure in performing each and every job. In addition to the supervisor, the operator should be familiar with the proper guarding of the point of operation. Never permit an operator to start a job without complete instructions from his immediate supervisor.

NEMA Control Wiring Diagrams
Press Brake Control / Model 3400

WARNING on LINEAR LIMIT SWITCH INSTALLATION

Control Reliability requires that you must never actuate LIMIT SWITCHES from the same actuating device (i.e. same Strike Plate or mechanical cam). All LIMIT SWITCHES cross check each other and so much be fully independent from each other. If the same actuating device is used between multiple LIMIT SWITCHES, then a method must be used to check for failure of the actuating device that meets Control Reliability standards.

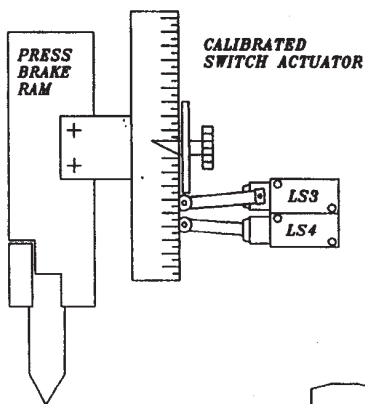

LS1 AND LS2 LIMIT SWITCHES MUST BE ACTUATED NEAR THE TOP OF THE STROKE. IF THERE IS AN EXPOSED CRANKSHAFT THAT MAKES ONE REVOLUTION FOR EVERY STROKE OF THE PRESS, CAMS SIMILAR TO THE ONES SHOWN IN ILLUSTRATION "A" SHOULD BE USED. THE DWELL OF THE CAMS WILL VARY DEPENDING ON THE STOPPING TIME OF THE PRESS. IF ADDITIONAL SWITCHES ARE REQUIRED, REFER TO TIMING CHART ON ELECTRICAL DRAWING.

IF AN EXPOSED CRANKSHAFT IS NOT AVAILABLE AS IS OFTEN THE CASE ON CHICAGO PRESS BRAKES, AN ACTUATOR ARM SIMILAR TO THE ONE SHOWN IN ILLUSTRATION "B" MUST BE USED. NORMALLY THE CORRECT SEQUENCE CAN BE OBTAINED BY ADJUSTING THE ANGLE OF THE ARMS SO LS2 IS ACTUATED ON THE UPSTROKE BEFORE LS1. LS1 IS ACTUALLY THE SWITCH THAT SIGNALS THE PRESS TO STOP.

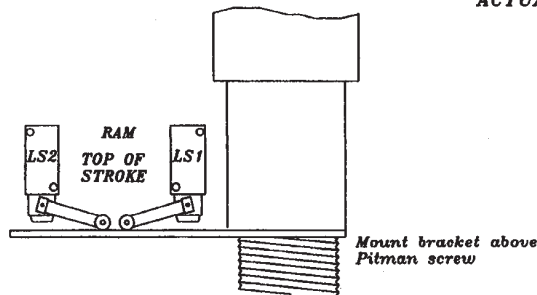

ILLUSTRATION B

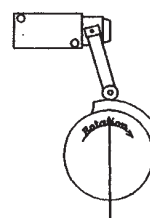
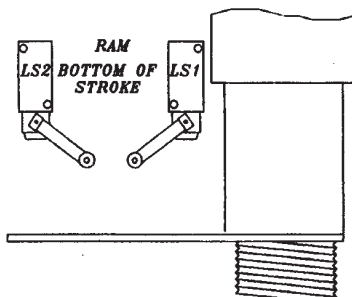
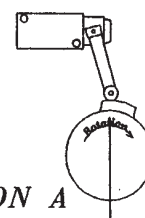

ILLUSTRATION A



Top Dead Center

IF ADDITIONAL SWITCHES ARE REQUIRED SUCH AS LS4 AND LS5, MAKE CAMS IN A SIMILAR MANNER AND ACTUATE ACCORDING TO TIMING CHART ON ELECTRICAL DRAWING.

IF ROTARY SWITCH IS USED, ADJUST CAMS ACCORDING TO TIMING CHART ON ELECTRICAL DRAWING.

INSTALLATION INSTRUCTIONS
CALIBRATED ACTUATOR LS1-LS2

TRIAD
CONTROLS

DWG# 60003

Appendix C: Drawings NEMA Control Wiring Diagrams Press Brake Control / Model 3400

WARNING on LINEAR LIMIT SWITCH INSTALLATION

Control Reliability requires that you must never actuate LIMIT SWITCHES from the same actuating device (i.e. same Strike Plate or mechanical cam). All LIMIT SWITCHES cross check each other and so must be fully independent from each other. If the same actuating device is used between multiple LIMIT SWITCHES, then a method must be used to check for failure of the actuating device that meets Control Reliability standards.

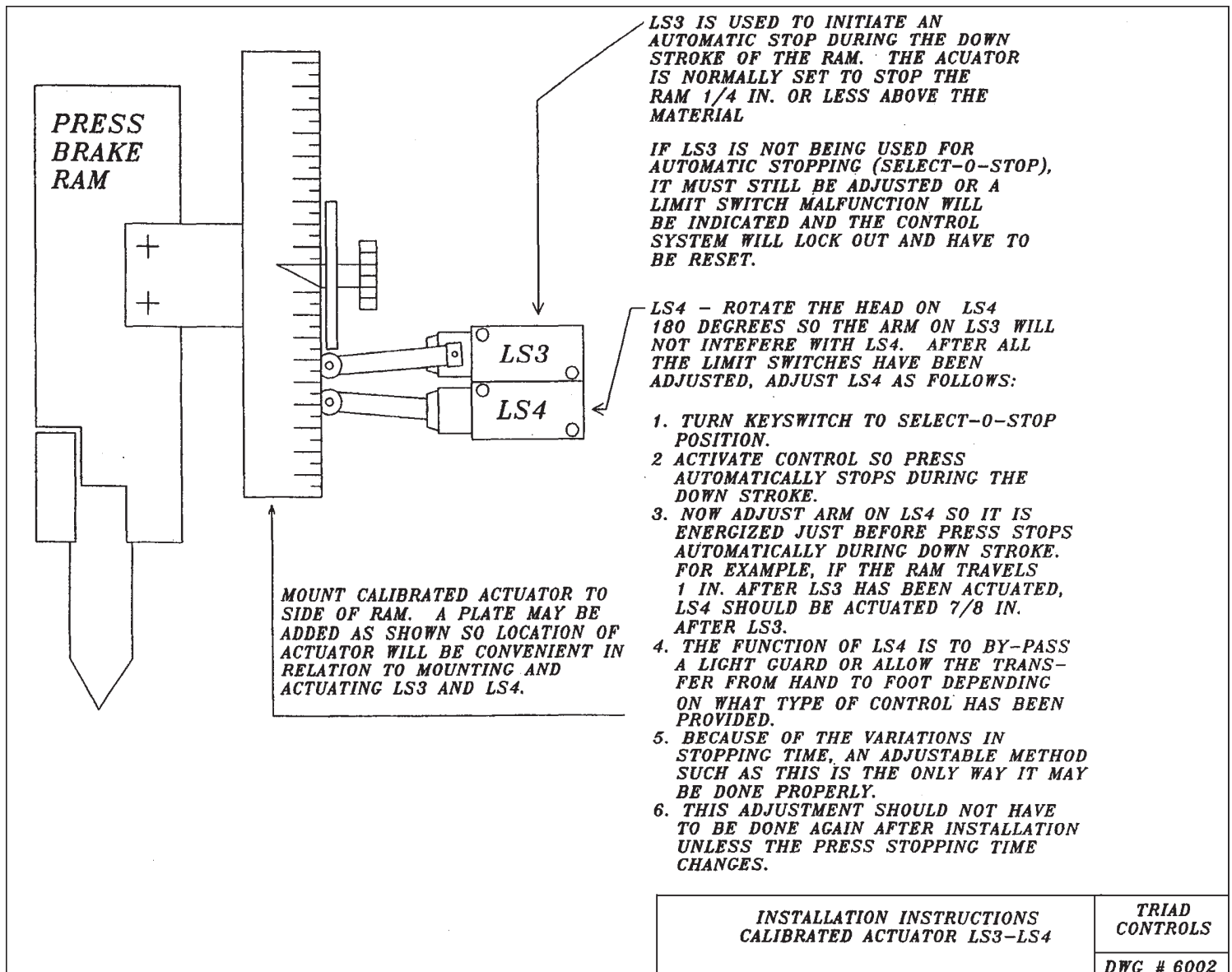

Appendix C:
 Drawings
 NEMA Control Wiring Diagrams
 Press Brake Control / Model 3400

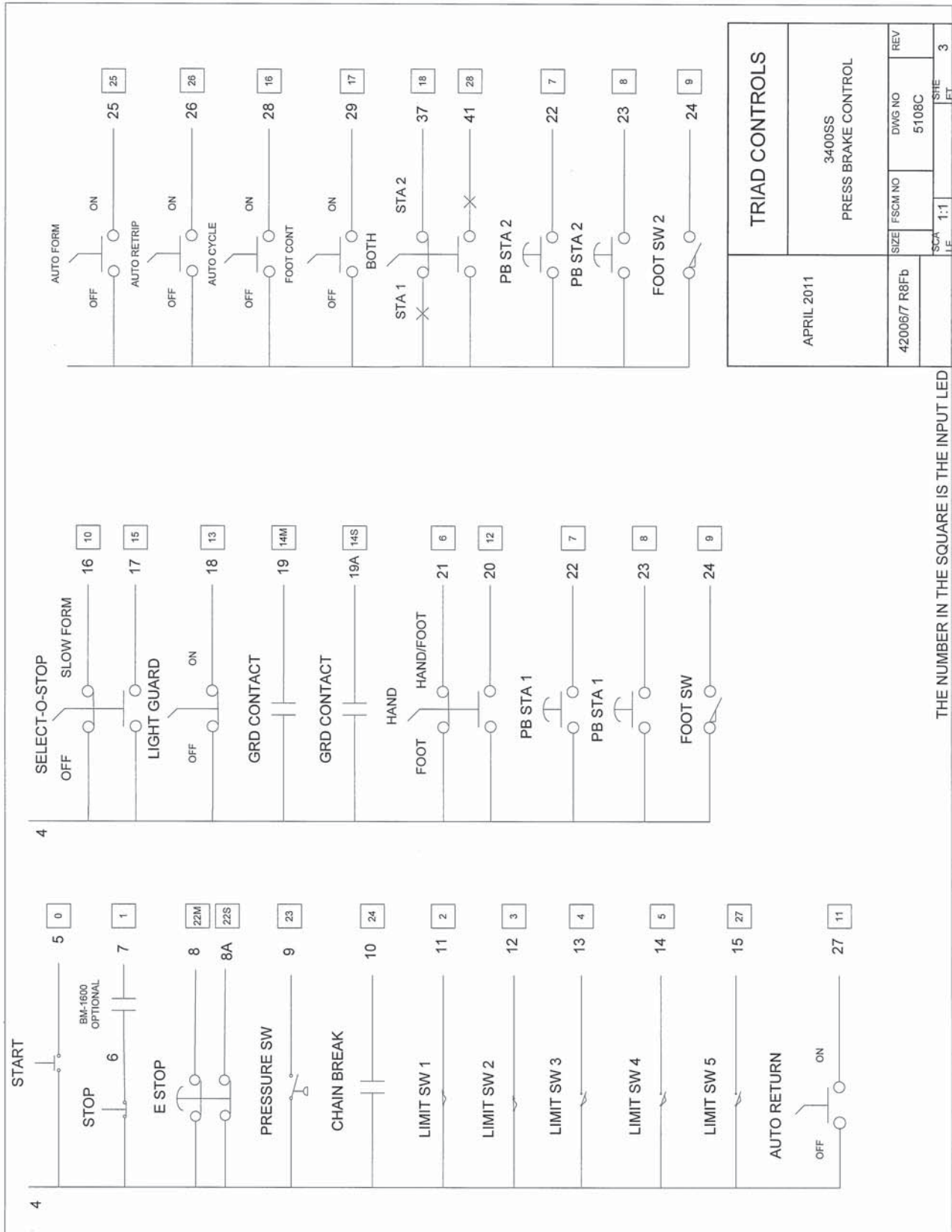

Appendix C: Drawings NEMA Control Wiring Diagrams Press Brake Control / Model 3400

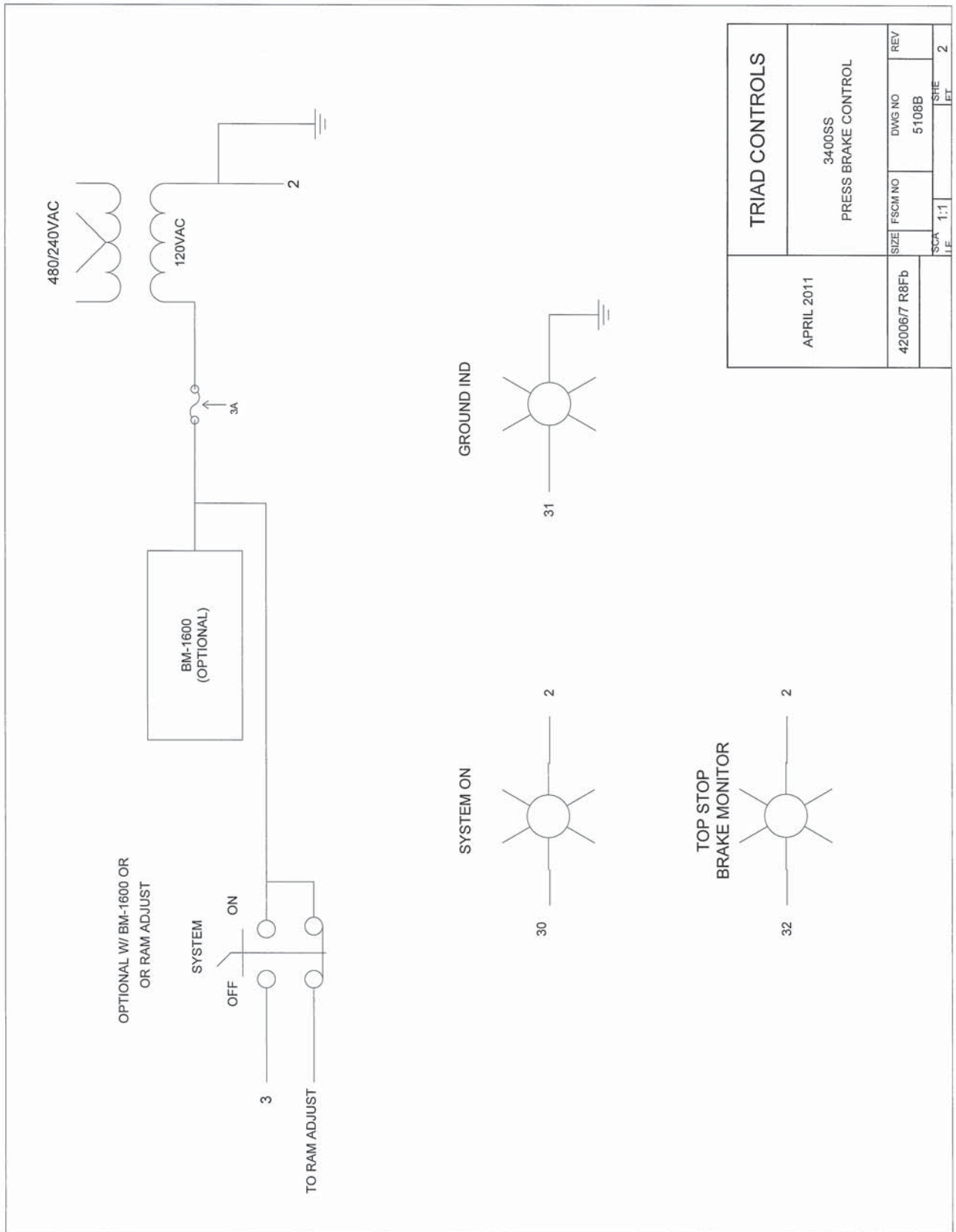

Appendix C: Drawings NEMA Control Wiring Diagrams Press Brake Control / Model 3400

Warning: You must use Dual Safety Valves. Please refer to the front of this manual, "Warning on Actuating Press Valves" for detailed requirements.

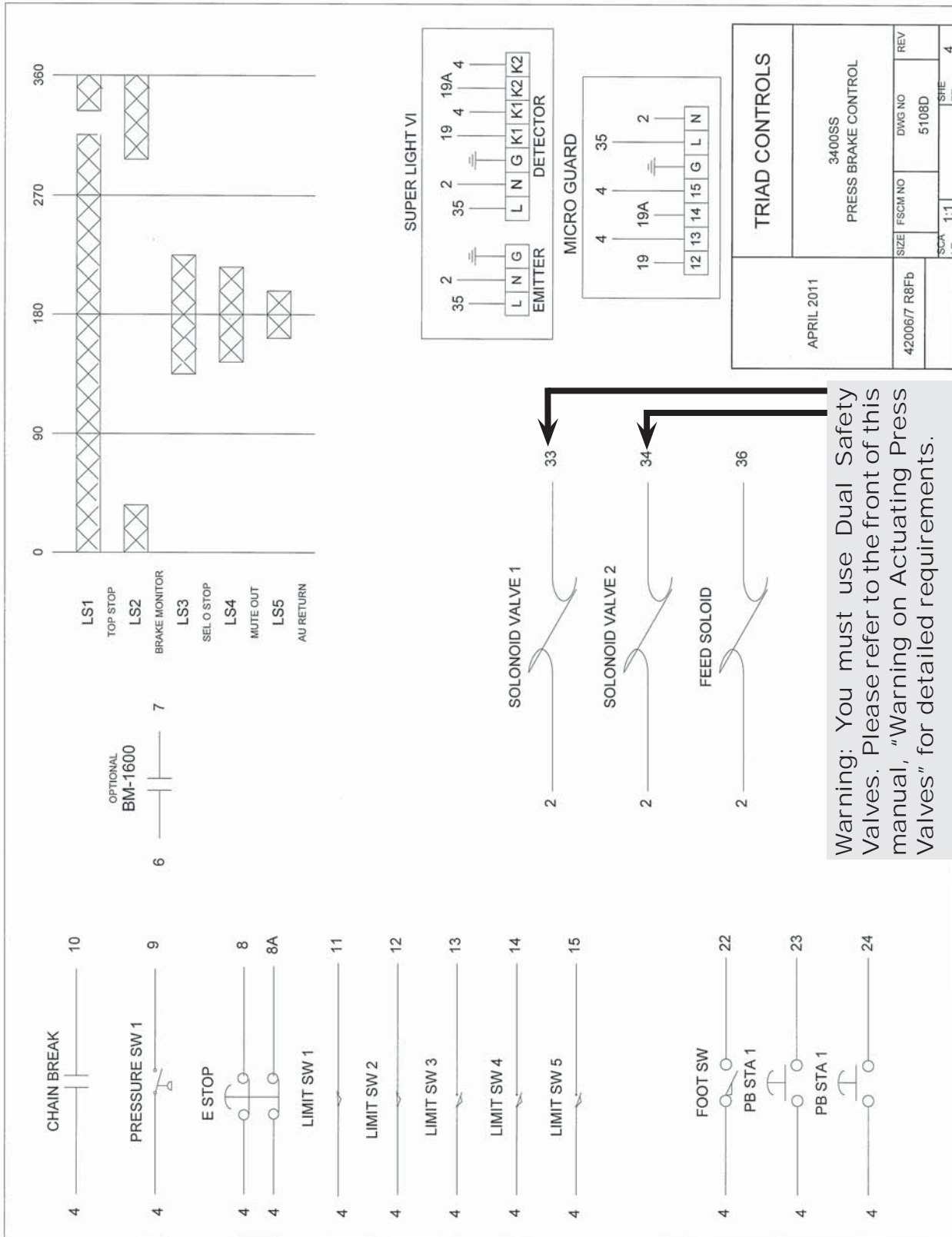

Appendix C:
 Drawings
 NEMA Control Wiring Diagrams
 Press Brake Control / Model 3400

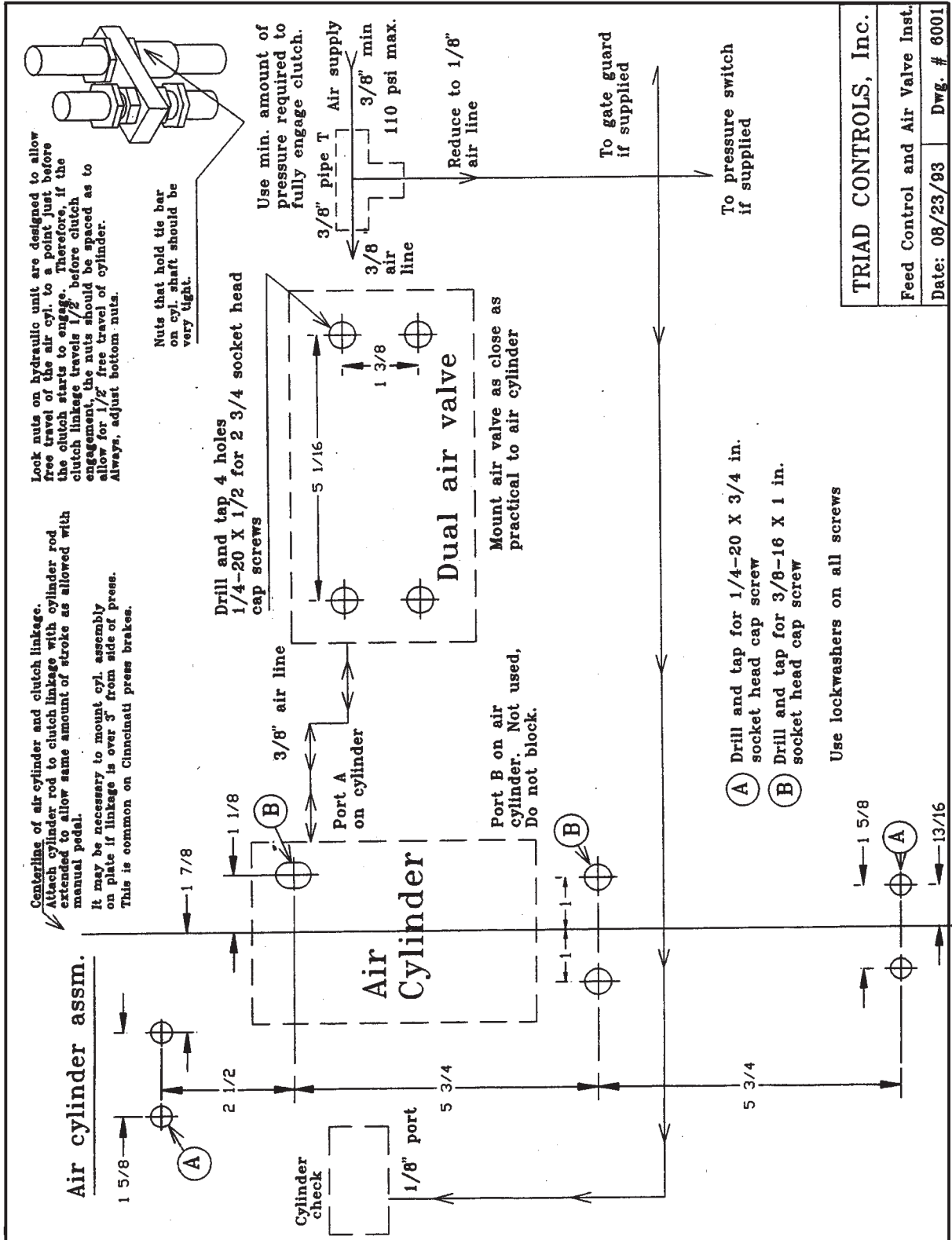

TRIAD CONTROLS, Inc.	
Feed Control and Air Valve Inst.	
Date: 08/23/93	Dwg. # 6001

WARRANTY

Manufacturer warrants that this product will be free from defects in material and workmanship for a period of one year from the date of shipment thereof. Within the warranty period, manufacturer will repair or replace such products which are returned to it with shipping charges prepaid and which will be disclosed as defective upon examination by the manufacturer. This warranty will not apply to any product which will have been subject to misuse, negligence, accident, restriction, and use not in accordance with manufacturer's instructions or which will have been altered or repaired by persons other than the authorized agent or employees of the manufacturer.

DISCLAIMER

The provisions of the paragraph "Warranty" are the sole obligations of the manufacturer and exclude all other warranties of merchantability, expressed or implied.

Further, there are no warranties which extend beyond the above warranty.

LIMITATION OF LIABILITY

In the event of any claim or breach of any obligations of manufacturer under any order, whether expressed or implied, and particularly in the event of any claim or a breach of the warranty or warranties contained in the paragraph "Warranty" or of any other warranties, expressed or implied which might, despite the paragraph entitled "Disclaimer," be determined to be incorporated in any order, the company shall under no circumstances be liable for any consequential or special damages, either in law or in equity, or for losses or expenses or claims for the same arising from the use of, or inability to use, the products of the manufacturer for any purpose whatsoever.

WARNING: The entire machine safety system must be tested at the start of every shift. Machine testing should include: (1) proper machine operation and stopping capability; and (2) verification of proper installation and settings of all point of operation guards and devices before the operation is released for production.



Triad Controls, Inc.

Sales and Marketing Offices

United States

Triad Controls, Inc.
P.O. Box 99875
Pittsburgh, PA 15233
Toll Free: 800-937-4334
Direct: 412-262-1115
Fax: 412-262-1197

Canada

Triad Controls, Inc.
8-1734 Orangebrook Court
Pickering, Ontario L1W 3G8
Toll Free: 888-285-8885
Direct: 905-831-1111
Fax: 905-831-4064

Customer Service (630) 443-9320

We have designed our equipment to the very highest performance and safety standards known to the current technological state of the art, as evidenced by our U.S.A. and foreign patents issued and pending. However, the installation, usage, suitability, and fitness of our equipment for any purpose, known or unknown, is interdependent upon the performance of other equipment not manufactured, installed, secured or maintained by Triad Controls, Inc.

We cannot and do not accept responsibility for any overall system performance when factors, such as these, are beyond our control.

www.com.com

sales@triadcontrols.com
service@triadcontrols.com